

# WEB STIFFENERS

If web stiffeners are required, follow the procedures below:

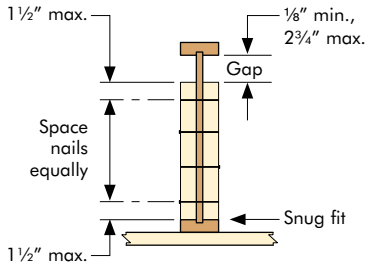

When required, web stiffeners must be properly installed or the following problems may occur:

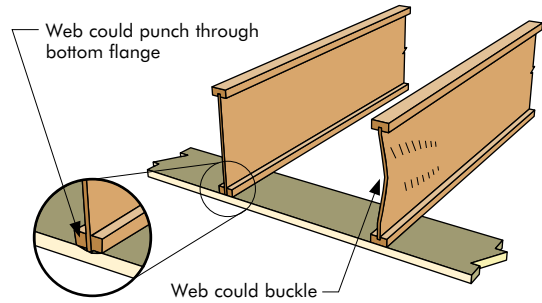

## NAIL QUANTITIES FOR WEB STIFFENER ATTACHMENT

Joist Depth	CFI-77		CFI-90	
	Min. 0.131" x 2 1/2" Nails		Min. 0.131" x 3 1/2" Nails	
	End or Intermediate	End or Intermediate	End or Intermediate	End or Intermediate
11 7/8"	4	4	4	4
14"	4	4	4	4
16"	4	4	4	4
18"	8	8	8	8
20"	8	8	8	8

Web stiffeners for CFI-77 joists must be 7/8" x 2 5/16" sheathing (with face grain vertical). Web stiffeners for CFI-90 and CFI-H90 joists shall be 2x4 material of construction grade or better.

Web stiffener requirements will vary based on joist series and depth; they are always required at bearing on joists 20" in depth or greater. See plan or details for requirements specific to the joists being used on this project.

# PANEL ASSEMBLY

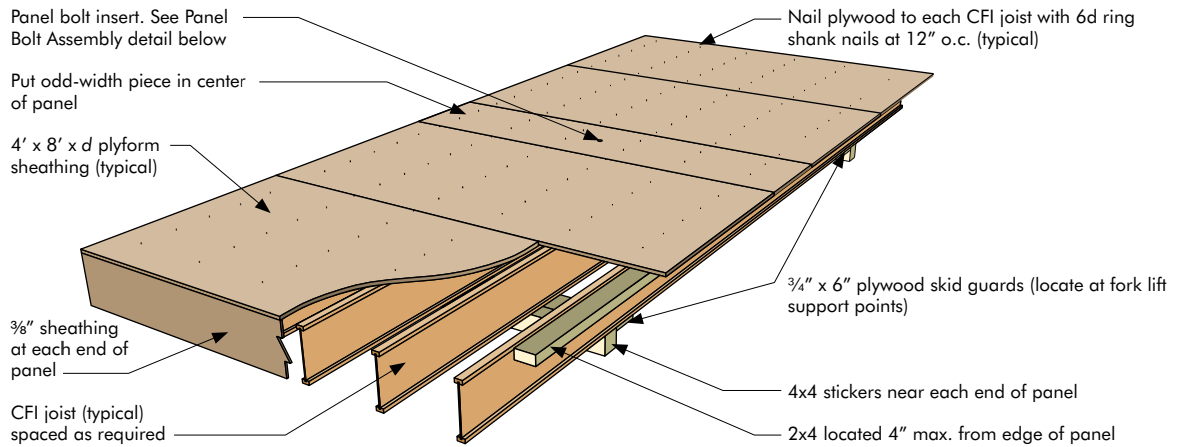

# PANEL BOLT ASSEMBLY

